

ORDINANCE 1992-08  
REVISED 1-19-04 (Revision #1)  
REVISED 3-2-15 (Revision #2)

STREET EXCAVATIONS AND OPENINGS

I. DEFINITIONS

A. Definitions

II. PERMIT TERMS AND CONDITIONS

- A. Compliance with Regulations, Exception
- B. Permit Required
- C. Conditions of Granting Permit
- D. Special Conditions
- E. Acceptance of Permit
- F. Expiration/Extension of Permit
- G. Revocation of Permit
- H. Denial of Permit
- I. Township's Right to Complete Restoration

III. REGULATIONS

- A. Application
- B. Fees and Deposit
- C. Bonding
- D. Insurance
- E. Prohibitions
- F. Inspection

IV. SPECIFICATIONS

- A. Scope
- B. Materials
- C. Construction

V. PENALTIES; VALIDITY

- A. Penalties
- B. Validity

## I. DEFINITIONS

- A. The following words and terms, when used in this Ordinance, have the following meanings, unless the context clearly indicates otherwise:
1. APPLICANT - Shall mean any person who makes application for a permit.
  2. BOARD - Shall mean the Summit Township Board of Supervisors.
  3. EMERGENCY - Shall mean an unforeseen occurrence or combination of circumstances which calls for immediate action or remedy.
  4. ENGINEER - Shall mean the Township Engineer of Summit Township or his authorized representative.
  5. PAVEMENT - Shall mean the combination of subbase, base course, and surface course placed on a subgrade to support the traffic load or to distribute it to the roadbed, or both.
  6. PENNDOT - Shall mean the Pennsylvania Department of Transportation.
  7. PERMIT - Shall mean a Street Opening Permit issued by the Township to an owner of a utility or facility located within a Township street right-of-way.
  8. PERMITTEE - Shall mean any person who has been issued a Permit and has agreed to fulfill all the terms of this Ordinance.
  9. PERSON - Shall mean an individual, firm, partnership, association, corporation, authority or political subdivision.
  10. STREET - Shall mean any and all streets, roads, highways and alleys within or abutting the Township of Summit, for the full width thereof from right-of-way line to right-of-way line, including pavement, curbs, walks, lawns and other facilities usually found within the right-of-way lines provided, however, that State highways shall not be streets within the provisions of this chapter.
  11. STREET OPENING/CUT - Shall mean any and all work contemplated by Section II(A) of this Ordinance.
  12. TOWNSHIP - Shall mean Summit Township, Erie County, Pennsylvania.

## II. PERMIT TERMS AND CONDITIONS

### A. COMPLIANCE WITH REGULATIONS; EXCEPTION

It shall be unlawful for any person to make any street opening without first securing a permit therefore from the Township of Summit. Provided, however, any person maintaining existing pipes, lines, or underground conduits, in or under the surface of any street may proceed with an excavation or opening without a permit when emergency circumstances demand the work be done immediately for the preservation of the public health, safety or welfare, such that a permit could not be reasonable and practically obtained beforehand. Such person, however, shall thereafter apply for a permit on the next regular business day of the Township after emergency repairs have commenced, and said permit will be retroactive to the date when work began.

### B. PERMIT REQUIRED

Any person desiring to open a street within the street right-of-way lines and including the pavement, curb or shoulder areas of such street shall first make application to the Township for a Permit to do such work, pay the permit fees, post the required bond or deposit, obtain and show proof of required insurance and give notices as hereinafter required.

### C. CONDITIONS OF GRANTING PERMIT

The granting of any Street Opening Permit shall confer a right upon the permittee, subject to the terms and conditions of the Permit, to temporarily occupy and use the street right-of-way during the course of construction work covered by the Permit, subject in every case to the specific right of the Township to require temporary or permanent relocation or removal of any of the facilities entirely at the permittee's expense in the event said facilities are in conflict with the Township's interest or the public interest in use of the street.

### D. SPECIAL CONDITIONS

In granting any Permit, the Township may attach such special conditions thereto as may be reasonably necessary to protect public and private property.

### E. ACCEPTANCE OF PERMIT

By accepting the Permit, the applicant agrees to perform the work in accordance with the terms and conditions of the Permit, and any special conditions which may be attached thereto, and to save and hold harmless the Township, its officers, employees and agents from any costs, damages and liabilities which may result from the permitted work. Permittee agrees to provide advanced notice to the Township, PA One Call, local emergency services

dispatch centers, and the Fort LeBoeuf School District of traffic restrictions to be caused by the street opening/cut. Notice shall include date(s) and time(s) of activities and proposed traffic restrictions.

F. EXPIRATION/EXTENSION OF PERMIT

Every Permit issued hereunder shall expire on the date specified in the Permit. If the permittee is unable to complete the work by the expiration date, he shall, prior to the expiration of the Permit, present in writing to the Township a request, in letter form, for an extension of time, setting forth therein the reasons for the requested extension. A supplemental fee payable to "Summit Township" shall accompany the application to defray the costs of processing and filing the application.

G. REVOCAION OF PERMIT

All Street Opening Permits are subject to revocation at any time by the Township after written notice for:

1. Violation of any condition of the Permits.
2. Violation of any provision of this Ordinance or law relating to the work.
3. The existence of any condition or the doing of any act constituting or creating a nuisance or endangering the lives or property of others.

Written notice of such violation shall be served upon the person to whom the permit was granted, or his agent or employee engaged in the work. Such notice shall also contain a brief statement of the reasons for revoking such Permit. Notice may be given by personal delivery thereof to the person to be notified or by the United States mail, addressed to such person to be notified.

Upon revocation of the Permit, all fees shall be forfeited by the permittee.

H. DENIAL OF PERMIT

The Township may refuse the issuance of the Street Opening Permit to an applicant if it is determined that the applicant is not qualified to perform the work, if the applicant does not comply with the bonding, insurance and remittance of fees requirements contained in this Ordinance, or if the applicant has a history of noncompliance with past Street Opening Permits and/or this Ordinance.

I. TOWNSHIP'S RIGHT TO COMPLETE RESTORATION

Whenever final restoration or repairs, including paving, are not completed to the satisfaction of the Township, the Township reserves the right, after notice

to the permittee, to complete the work for which the permit has been issued, including removal of substandard work, and the permittee agrees to reimburse the Township the actual cost thereof, plus 15%. The decision of the Township to exercise its right to have final restoration or repairs completed shall not revoke the Permit, and all other responsibilities of the permittee shall remain in full force and effect.

### III. REGULATIONS

#### A. APPLICATION

Any person intending to make a street opening shall make written application to the Township on a form provided for that purpose. No work shall commence until the Township has approved the application and issued a Permit, excepting emergency work as provided under Section IIA hereof. Each application shall include an accurate drawing clearly showing the extent of the proposed street opening and the location and depth of subsurface facilities to be installed, and, when required by the Township, the locations and depths of all other subsurface facilities in the vicinity of the work. A separate application must be submitted for each street opening except where multiple street openings are required within a single block for a single project.

#### B. FEES AND DEPOSIT

The applicant shall pay a fee or fees, and shall be required to make a deposit or provide a bond, and must produce certificates of insurance at the time of the issuance of the Street Opening Permit per fee a schedule adopted by the Board.

#### C. BONDING

All persons who desire to open a street, except contractors contracted by the Township, shall be required to furnish financial security in the form of cash, irrevocable letter of credit, escrow account, or bond from a bonding company or lending institution authorized to conduct such business within the Commonwealth of Pennsylvania. Persons such as public utility companies who anticipate the opening of streets on a more frequent basis may provide bonding on a yearly basis. If the value of the actual street openings completed during a year exceeds 75% of the yearly bond amount, the bond amount will be required to be increased accordingly. All such financial security will be required to be in effect for the duration of the work and for the first 12 months thereafter.

The total amount of the bonding will be computed per a calculation schedule adopted by the Board.

D. INSURANCE

All applicants who desire to open a street within the right-of-way of such street will be required to secure certificates of insurance, copies of which shall be submitted to the Township. The certificates of insurance shall be issued by insurance companies approved and admitted to do business in the Commonwealth of Pennsylvania. Minimum amounts of insurance to be maintained are as follows:

MANUFACTURER'S OR CONTRACTOR'S LIABILITY

Bodily Injury	\$1,000,000	Per Occurrence
Property Damage	\$1,000,000	Per Occurrence
	\$2,000,000	Aggregate

CONTRACTOR'S PROTECTIVE LIABILITY

Bodily Injury	\$1,000,000	Per Occurrence
Property Damage	\$1,000,000	Per Occurrence
	\$2,000,000	Aggregate

COMPLETED OPERATIONS

Bodily Injury	\$1,000,000	Per Occurrence
Property Damage	\$1,000,000	Per Occurrence
	\$2,000,000	Aggregate

CONTRACTOR'S AUTOMOTIVE LIABILITY

Bodily Injury	\$500,000.	Per Occurrence
Property Damage	\$250,000.	Per Occurrence
	\$500,000.	Aggregate

The applicant shall save and hold harmless the Township, its employees and agents from any and all damages and liability by reason of personal injury or property damage arising from the work done by the applicant under the provisions of this ordinance. Furthermore the Township, its employees and agents shall be named as additional insureds in the applicant's certificate of insurance.

E. PROHIBITIONS

Non-emergency street excavations and openings shall be prohibited unless special permission is obtained in writing from the Township:

- From November 1 to March 31

- For streets that have been newly constructed, reconstructed, reconditioned, or newly paved within the last three years.

F. INSPECTION

The Township and/or its duly authorized representatives shall have access to the work at all times, and the permittee shall provide proper facilities for such access.

The presence of Township employees or agents shall in no way relieve the permittee of the responsibilities included under the Permit or this Ordinance, or be of any warrant for the furnishing of substandard or unsuitable materials or workmanship. Permittee shall provide a minimum 24 hour advance notice to the Township prior to initiation of construction for a streetopening/cut.

IV. SPECIFICATIONS

A. SCOPE

The work to be included under this specification shall include all labor, materials, and equipment necessary for excavating and restoring the openings in streets in the Township of Summit, Erie County, Pennsylvania.

B. MATERIALS

Excavation Backfill -

PENNDOT No. 2A gradation aggregate consisting of hard, tough, durable, uncoated, inert particles reasonably free from clay, silt, vegetation, or other substances determined to be deleterious and in accordance with the latest edition of PENNDOT Pub. 408, Section 703.2

Superpave Asphalt Mixture Design, Standard Construction, HMA Base Course -

In accordance with the latest edition of PENNDOT Pub. 408, Section 309.

Superpave Asphalt Mixture Design, Standard Construction, WMA Base Course -

In accordance with the latest edition of PENNDOT Pub. 408, Section 311.

Superpave Mixture Design, Standard and RPS Construction

of Plant-Mixed HMA Courses-	In accordance with the most recent edition of PENNDOT Pub. 408, Section 409.
Superpave Mixture Design, Standard and RPS Construcion of Plant-Mixed HMA Fine-Graded Courses -	In accordance with the most recent edition of PENNDOT Pub. 408, Section 410.
Superpave Mixture Design, Standard and RPS Construction of Plant-Mixed WMA Courses-	In accordance with the most recent edition of PENNDOT Pub. 408, Section 411.
Bituminous Tack Coat -	Emulsified asphalt, Class AE-T bituminous bonding material in accordance with the most recent edition of PENNDOT Pub. 408, Section 460.
Cement Concrete -	Class AA cement concrete having a minimum 7- day compressive strength of 3,000 psi and 28 day compressive strength of 3,750 psi and in accordance with the most recent edition of PENNDOT Pub. 408, Section 704.
Reinforcement Steel -	Grade 60 reinforcement steel in accordance with the latest edition of PENNDOT Pub. 408, Section 709.
Asphalt Sealing Material -	In accordance with the latest edition of PENNDOT Pub. 408, Section 469.
Stockpiled Topsoil -	In accordance with the most recent edition of PENNDOT Pub. 408, Section 801.
Furnished Topsoil -	In accordance with the most recent edition of PENNDOT Pub. 408, Section 802.



Seeding and Soil Supplements -	Formula B conforming with the most recent edition of PENNDOT Pub. 408, Section 804.
Mulch -	In accordance with the most recent edition of PENNDOT Pub. 408, Section 805.
Plants, planting and transplanting -	In accordance with the most recent edition of PENNDOT Pub. 408, Section 808.
Sodding -	In accordance with the most recent edition of PENNDOT Pub. 408, Section 809.

C. CONSTRUCTION

All construction shall be in accordance with the applicable sections of the most recent edition of PENNDOT Pub. 408 unless otherwise specifically noted on the Permit in Section IID.

The permittee shall conform to the Pennsylvania One Call System (Act 187 of 1996, 73 P.S. §176 et seq.) and take all precautions necessary to avoid damage to other utility lines and to public and private property. In the event that damage does occur, the permittee shall promptly and satisfactorily repair all damage and restore the utility and/or property to a satisfactory condition.

Where excavations are performed for new facilities, or for repairs to take place within the pavement, the street pavement shall be sawcut to neat lines prior to excavation. Sawing shall be performed for the full depth of the bituminous or concrete portion of the pavement section.

All excavated material must be removed from the site and disposed of off-site in accordance with all local, state and federal regulations. A material suitable for bedding or insulation may be used for backfill around and over the facility to a height not to exceed one foot over the top of the facility and shall be compacted to a minimum of 95% of the materials dry weight density as determined in accordance with ASTM D698. The bedding and/or insulation material must be free from all vegetation, organic matter and frozen material. The remainder of the excavation shall be backfilled with PENNDOT No. 2A aggregate placed in maximum 6 inch loose lifts and thoroughly compacted to a minimum of 95% of the materials dry weight density as determined in accordance with ASTM D698. Compaction shall be achieved utilizing approved pneumatic and/or vibratory

equipment. If wackers or tampers are used in smaller excavations, the backfill layers shall not exceed a maximum 4 inch loose lift.

Once the backfilling has been completed, the existing pavement shall be sawcut full depth an additional 1 foot from all sides of the excavation. The excavated pavement area shall be restored by in kind replacement of the concrete and/or asphalt constituting the existing pavement. If the existing street pavement consists of a Slurry Seal (tar and chip), the excavated pavement shall be restored as shown on the attached details. The sawcut face of the existing asphalt shall be cleaned and prepared with bituminous tack coat prior to placement of bituminous materials. The finished surface of restored asphalt pavements shall be at an elevation 3/16 of an inch higher than the adjacent existing pavement. The joint between new and existing asphalt pavements shall be sealed in accordance with PADOT Pub. 408, Section 469.

If the pavement restoration is to consist entirely of concrete, the concrete shall be Class AA cement concrete conforming to the latest edition of PENNDOT Pub. 408, Section 704. The concrete shall be placed and cured in accordance with the latest edition of PENNDOT Pub. 408, Section 501.

The permittee shall be responsible to erect and maintain traffic control and safety devices in accordance with the latest edition of PENNDOT Pub. 213.

The permittee shall permanently repair all street openings immediately upon completion of the permitted work except when unfavorable weather conditions prevent the proper construction of such repairs. In such cases, the opening shall be repaired temporarily as directed by the Township and as soon as suitable weather conditions permit, but no longer than six (6) months after completion of the work, permanent repairs shall be completed.

The permittee is responsible for providing a smooth surface and proper drainage at all times over the street opening and shall make required repairs as directed by the Township.

The surface of the street shall be kept clear of all stones and debris at all times. Removal of debris shall be performed by sweeping or other methods as required.

The permittee will provide a one year guarantee for all repairs completed to streets within the Township. The one year guarantee period shall begin on the date of final approval of the repaired work by the Township. The Township shall provide the approval in letterform to the permittee. If settlement occurs or the pavement repair fails in any fashion during the one year guarantee period, the permittee will be required to immediately correct such deficiencies at no expense to the Township.

## V. PENALTIES; VALIDITY

### A. PENALTIES

Any person violating any provision of this Ordinance shall, upon conviction thereof, be sentenced to pay a fine of not less than \$100.00, nor more than \$600.00 and costs of prosecution including reasonable attorney fees, and, in default of payment of such fine and costs, to imprisonment of not less than 5 days, nor more than 30 days. Provided, each violation of any provision of this Ordinance, and each day the same is continued, shall be deemed a separate offense.

### B. VALIDITY

The provisions of this Ordinance are severable. If any section, clause, sentence, part or provision thereof shall be held illegal, invalid or unconstitutional by any court of competent jurisdiction, such decision of the court shall not affect or impair any of the remaining sections, clauses, sentences, parts or provisions of this Ordinance. It is hereby declared to be the intent of the Board of Supervisors that this Ordinance would have been adopted, if such illegal, invalid or unconstitutional section, clause, sentence, part or provision had not been included herein.

## BONDING SCHEDULE

\$2,000 Bond	For openings up to 100 square feet in size plus \$1,000 for every 100 square feet over 100 sq. feet with excavated depth of five (5) feet or less.
\$4,000 Bond	For openings up to 100 square feet in size plus \$1,000 for every 100 sq. feet over 100 sq. feet, and an excavated depth of between five(5) to ten(10) feet.
\$8,000 Bond	For openings up to 100 square feet in size plus \$1,000 for every 100 sq. feet over 100 sq. feet, and an excavated depth of over ten(10) feet.

Duly adopted by ordinance this 2nd day of March, 2015, known as Ordinance No. 1992-08 Revision #2.

SUMMIT TOWNSHIP SUPERVISORS

ATTEST:

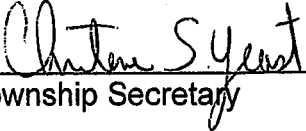
  
\_\_\_\_\_  
Township Secretary

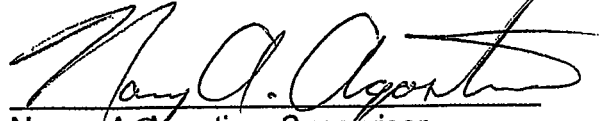
  
\_\_\_\_\_  
Nancy A. Agostine, Supervisor

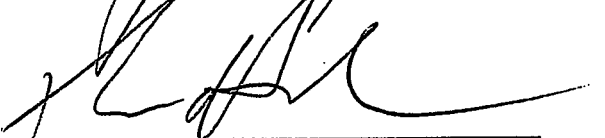
  
\_\_\_\_\_  
Thomas H. Church, Jr., Supervisor

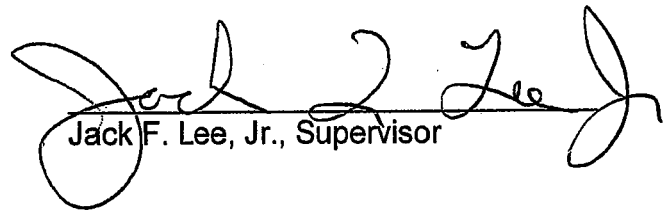
  
\_\_\_\_\_  
Jack F. Lee, Jr., Supervisor

seal

# STREET OPENING RESTORATION DETAILS

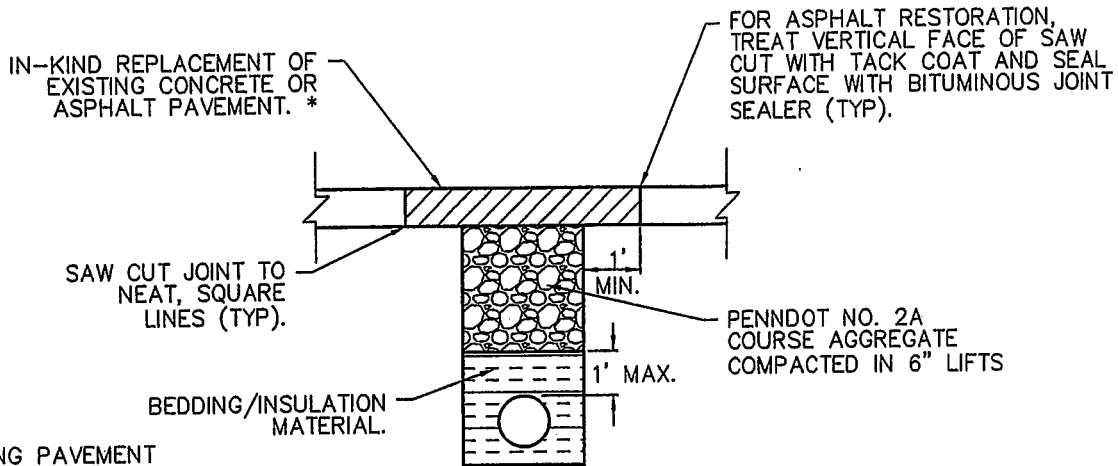

\* IF EXISTING PAVEMENT CONSISTS OF SLURRY SEAL (TAR & CHIP) THE PAVEMENT RESTORATION SHALL CONSIST OF 5" MIN. BASE COURSE AND 1 1/2" MIN. WEARING COURSE.

ALL MATERIALS AND CONSTRUCTION SHALL BE IN ACCORDANCE WITH CURRENT PENNDOT PUBLICATION 408 STANDARDS.

## PERMANENT STREET OPENING RESTORATION DETAILS

N.T.S.

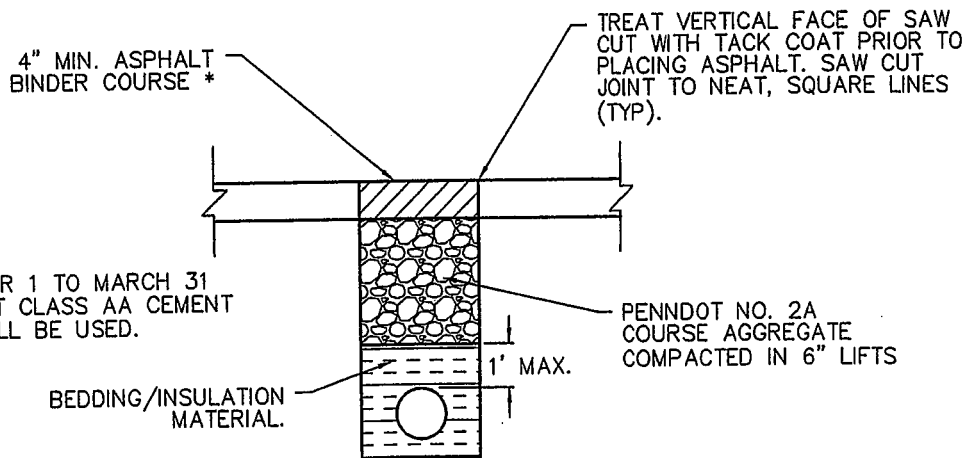

\* FROM NOVEMBER 1 TO MARCH 31 6" OF PENNDOT CLASS AA CEMENT CONCRETE SHALL BE USED.

ALL MATERIALS AND CONSTRUCTION SHALL BE IN ACCORDANCE WITH CURRENT PENNDOT PUBLICATION 408 STANDARDS.

## TEMPORARY STREET OPENING RESTORATION DETAILS

N.T.S.

### SUMMIT TOWNSHIP

